

24M

Motor Grader



Cat® C18 ACERT™

Base Power (all gears) – Net	397 kW	533 hp
------------------------------	--------	--------

Moldboard

Width	7.3 m	24 ft
-------	-------	-------

Gross Vehicle Weight – Base

Total	62 457 kg	137,694 lb
Front Axle	18 862 kg	41,584 lb
Rear Axle	43 595 kg	96,110 lb

24M Motor Grader

The 24M delivers multiple technological breakthroughs to give you the best return on your investment.

Operator Station

- ✓ A technologically advanced cab, featuring joystick controls, provides unmatched comfort and visibility. **pg. 4**

Steering and Implement Controls

- ✓ Two joysticks offer precise control and unparalleled ease of operation. This advanced technology makes the 24M the most operator-friendly motor grader in the world. **pg. 6**

Engine

- ✓ The Cat® C18 engine with ACERT™ Technology delivers maximum power and efficiency while reducing the environmental impact. **pg. 7**

Integrated Electronic Solutions

- ✓ Full systems integration with advanced electronics including Cat® Messenger, AccuGrade™ blade control system and Cat® ET, create a “Smart Machine” that optimizes performance and availability. **pg. 13**

Safety

- ✓ Caterpillar has been and continues to be proactive in developing machines that meet or exceed safety standards. **pg. 14**

The 24M motor grader represents a revolution in operational efficiency and overall productivity, setting a new standard and building on a legacy of high quality you can trust.



Structures, Drawbar, Circle and Moldboard

The rugged construction of the 24M frame and DCM provides durability and maximum productivity. **pg. 8**

Power Train

- ✓ An electronically controlled power shift transmission assures smooth shifting and maximum power to the ground. A modular rear axle and hydraulic brakes simplify serviceability and reduce operating costs. **pg. 10**

Hydraulics

- ✓ The Electro-Hydraulic load-sensing system provides the foundation for advanced machine controls, enabling superior controllability, precise and predictable hydraulic movements, with the reliability customers expect from Caterpillar. **pg. 12**

Serviceability and Customer Support

Fast component replacement and minimum downtime are possible with Caterpillar's exceptional parts availability and dealers' advanced rebuild and repair capabilities. **pg. 16**



✓ *New Feature*

Operator Station

The 24M features a revolutionary cab design that provides unmatched comfort and ease of use, making the operator more confident and productive.



Advanced Joystick Controls.

Two electro-hydraulic joysticks reduce hand and wrist movement as much as 78% compared to conventional lever controls for greatly enhanced operator efficiency. The intuitive pattern is easy to learn, and provides the precise implement control you expect from Caterpillar.

Ripper Control. The ripper control is ergonomically positioned to allow simple, comfortable operation.

Visibility. The exceptional forward view is made possible by a unique raised cab design and a one-piece front window, improving operator confidence and productivity. The large side windows offer a clear view of the moldboard heel and tandem tires. A wide rear window provides good visibility behind the machine. Glare reducing paint on the front frame, lift arms and rear enclosure help reduce glare, resulting in safer operation at night.

In-Dash Instrument Cluster.

The instrument panel, with easy-to-read, high-visibility gauges and warning lamps, keeps the operator aware of critical system information.

Controls and Switches. Reliable, long-life rocker switches are located on the right side cab post and front instrument cluster, within easy reach for the operator. Controls and switches are backlit for increased safety during night time operations.

Cat Messenger. Cat Messenger provides real-time machine performance and diagnostic data. The operator can quickly view critical performance and operating information, in multiple languages, helping to maximize the life and productivity of the machine.

Low Interior Sound and Vibration Levels. Isolation mounts for the cab, engine and transmission significantly reduce sound and vibration. The quiet interior with low vibration levels provide a comfortable work environment.

Cat Comfort Series Seat. The Cat Comfort Series air suspension seat has an ergonomic high-back design, with extra thick contoured cushions and infinitely adjustable lumbar support that evenly distributes the operator's weight. Multiple seat controls and armrests are easy to adjust for optimal support and comfort all day.

Comfort and Convenience. Caterpillar has built the most comfortable cab in the industry by replacing the control levers and steering wheel with two joystick controls. Extra leg and foot room create a spacious, open cab.

Multiple adjustment capabilities for the arm rest, wrist rest and joystick pods help keep the operator comfortable throughout a long shift.



Modular HVAC System. The standard modular heating, ventilation and air conditioning system is fully integrated into the design of the cab. The modular design allows for easy replacement or repair with minimum downtime. Intelligent placement of vents provides consistent climate control and clear windows for every condition. The high-capacity system dehumidifies air and pressurizes the cab, circulating fresh air while sealing out dust.

Additional Cab Features. Additional cab features include cup holder, lighter, ashtray, coat hook, storage area, night time light and power port. Optional rear view camera, 25-amp power converter and satellite radio are also available.



Steering and Implement Controls

The 24M sets the new standard for motor grader operational efficiency.

Ease of Operation. The revolutionary joystick controls make the 24M easier to operate without sacrificing control. The intuitive joystick control pattern allows both new and experienced operators to become productive quickly.

Logical grouping of hydraulic functions in the joysticks allow any operator to easily control several functions at the same time. This allows the operator to be more productive and remain comfortable throughout the work shift.

Intuitive Steering Control. The 24M introduces a breakthrough in joystick steering control. This technology creates a direct relationship between the lean angle of the joystick and the turning angle of the steer tires.

A brake tensioning system holds the joystick in position until the operator moves it. In addition, the steering control automatically reduces steering sensitivity at higher ground speeds for comfortable and predictable control.

Electronic Throttle Control. Electronic Throttle Control (ETC) provides the operator with easy, precise, and consistent throttle operation. An automatic and manual mode on a single switch offers flexibility for different applications and operator preference.

Ripper Control Pod. An infinitely variable roller switch controls the rear ripper for easy and comfortable control.

Articulation Return-to-Center.

This exclusive feature automatically returns the machine to a straight frame position from any articulation angle with the touch of a single button. Return-to-Center helps improve productivity and safety by allowing the operator to focus on controlling the moldboard.



Left Joystick Functions. The left joystick primarily controls the machine direction and speed.

- 1 – Steering: Lean joystick left and right
- 2 – Articulation: Twist joystick left and right
- 3 – Articulation Return to Center: Yellow thumb button
- 4 – Wheel Lean: Two black thumb buttons
- 5 – Direction: Index trigger shifts transmission to forward, neutral or reverse
- 6 – Gear Selection: Two yellow thumb buttons upshift and downshift
- 7 – Left moldboard lift cylinder: Push joystick to lower, pull joystick to raise
 - Left moldboard lift cylinder float: Pushing joystick through detent engages float



Right Joystick Functions. The right joystick primarily controls the Drawbar, Circle and Moldboard functions.

- 1 – Right moldboard lift cylinder: Push joystick to lower, pull joystick to raise
 - Right moldboard lift cylinder float: Pushing joystick through detent engages float
- 2 – Moldboard slide: Lean joystick left and right
- 3 – Circle turn: Twist joystick left and right
- 4 – Moldboard tip: Thumb switch fore and aft
- 5 – Drawbar center shift: Thumb switch left and right
- 6 – Electronic Throttle Control: Top trigger button is resume and decrement
- 7 – Differential Lock/Unlock: Bottom trigger button

Engine

The 24M utilizes ACERT™ Technology to deliver maximum power and efficiency while reducing the environmental impact.



ACERT™ Technology. ACERT™ Technology allows Cat engines to supply more power per unit of displacement without causing premature wear. This breakthrough technology reduces emissions during the combustion process by using advanced technology in the air and fuel systems, in conjunction with integrated electronics. ACERT Technology enhances overall engine performance while dramatically reducing exhaust emissions.

Fuel Delivery. The C18 engine with ACERT Technology uses multiple injection fuel delivery to precisely shape the combustion cycle. Several small ignitions lower combustion chamber temperatures, generate fewer emissions and optimize fuel combustion. Bottom line: more work output for your fuel cost.

Superior Lugging Performance. The Cat C18 engine meets specific performance requirements for 24M applications. Its superior torque and lugging capability can pull through sudden, short-term increases in loads, maintaining consistent, desirable grading speeds to get the work done faster without downshifting.

Hydraulic Demand Fan. The hydraulic demand fan automatically adjusts cooling fan speed according to engine cooling requirements. This system reduces demands on the engine, putting more horsepower to the ground and improving fuel efficiency.



Exhaust Emissions Compliant. The Cat C18 with ACERT Technology meets or exceeds all U.S. EPA Tier 3 and European Union Stage IIIa emissions control standards.

Compression Brake. The optional three phase compression brake enables higher travel speeds downhill, while reducing wear on brake components. This improves overall productivity and lowers maintenance costs.

Ether Starting Aid. This standard feature helps cold-weather startups in extreme temperatures. The system monitors engine coolant temperature to prevent ether from being injected into a hot engine.

Structures, Drawbar, Circle and Moldboard

Rugged structures and DCM design deliver maximum durability and productivity.



Front Frame Structure. Continuous top and bottom plate construction provides consistency and strength. The flanged box section design removes welds from high stress areas, improving reliability and durability.

Rear Frame Structure. Two steel plates running the full length of the rear frame are integrated with the box section hitch. This helps resist torsion loads and ensure structural durability. The integrated steel tube unifies the rear frame and supports the engine, while helping the frame withstand heavy-duty applications.

Articulation Hitch. A large tapered roller bearing at the lower and upper pivot carries loads evenly and smoothly. These joints are sealed to prevent contamination in this critical area. A mechanical locking pin prevents frame articulation to ensure safety when servicing or transporting the machine.

Push Plate/Counterweight. A front mounted push plate/counterweight can be added on the 24M.

Replaceable Wear Inserts. Tough, durable wear inserts reduce rotational friction for maximum circle torque and longer component life. They are located between the drawbar and circle, and between the support shoes and circle. High load-resistant brass wearstrips are placed between the blade mounting group and moldboard. This sacrificial wear system can be replaced easily and helps keep components tight for fine grading.

Adjustable Rear Circle Drive.

An adjustable rear circle drive makes serviceability easier and faster, and also reduces component wear by keeping components tight.

Drawbar Construction. The A-frame drawbar features a box-section design for high strength and optimum durability.

Circle Construction. A one piece forged steel circle is built to stand up to high stress loads and provide structural durability. Six bolt-on tooth segments can be individually replaced and serviced for reduced downtime and cost.

Yoke Plate. Full-length yoke plate gives strength, support and protection to the circle.

Aggressive Blade Angle. With a long wheelbase the operator can obtain aggressive moldboard angles, so material rolls more freely along the length of the blade. This is particularly helpful when handling very dry materials or cohesive soils. Better material control gets the job done faster, requires less power and saves fuel.

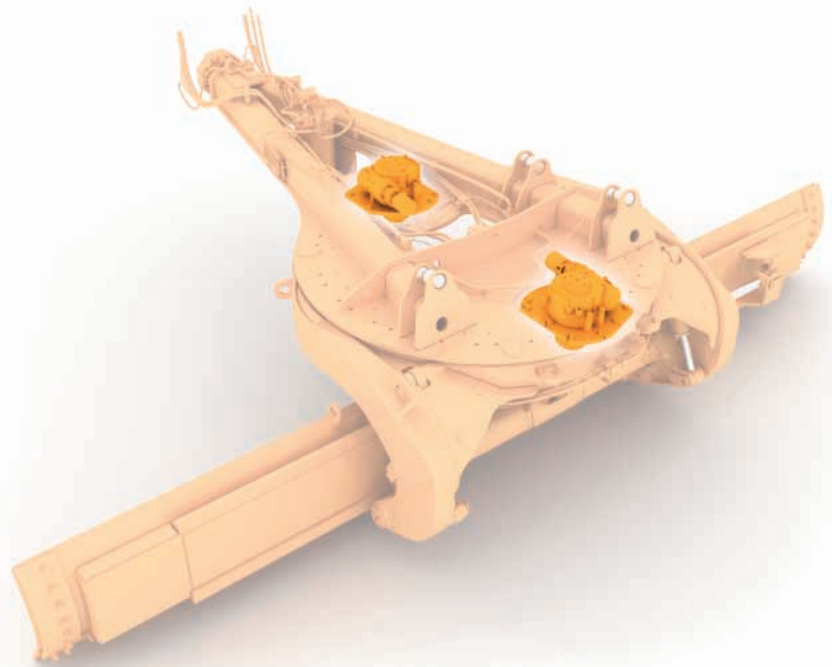

Moldboard. The optimal curvature and large throat clearance help move material quickly and efficiently. Heat-treated moldboard rails, hardened cutting edges and end bits, and large diameter bolts assure reliability and longer service life.

Ripper. The 24M standard ripper is made to penetrate tough material fast and rip thoroughly for easier material movement with the moldboard. The ripper includes three shanks with the ability to add four more if needed.



Power Train

Integrated, electronically controlled systems, deliver smooth reliable performance with reduced operating costs.



Smooth Shifting Transmission.

The 24M combines several key innovations to ensure smooth, powerful shifts throughout the gear range.

Electronically Controlled Shifting.

The full Electronic Clutch Pressure Control (ECPC) system smooths shifting between all gears and directional changes. This provides outstanding control and also extends the life of the transmission by reducing stress on gears.

Lockup Clutch Torque Converter.

Permits the machine to operate in direct drive for more efficient operation at higher torque converter output speeds.

Engine Over-Speed Protection.

Helps protect the transmission and extend component life by preventing downshifting until a safe travel speed has been established.

Planetary Transmission. Balanced planetary transmission with large diameter oil-cooled clutch packs provides superior load distribution and heat dissipation, resulting in longer transmission life.

Programmable Autoshift. The operator can easily customize various shift parameters through Cat Messenger to match the specific application requirement. This standard feature automatically shifts the transmission at optimal points so the operator can focus on the work, improving safety, productivity and ease of operation.

Modular Rear Axle. The 24M incorporates a bolt-on modular rear axle design, which offers easy access to differential components, improves serviceability and contamination control, and lowers operating costs.

Front Axle. The Caterpillar sealed spindle keeps the bearings free from contaminants and lubricated in a light-weight oil (1). This durable, low-maintenance design reduces your owning and operating costs. Two tapered roller bearings (2) support the wheel spindle. The Cat “Live Spindle” design places the larger tapered roller bearing outboard where the load is greater, extending bearing life.

Gear Selection. Six forward and three reverse gears give the operator a wide operating range. The specifically designed range of gears ensures maximum productivity in all mining applications.

Hydraulic Brakes. The oil bathed, multi-disc service brakes are hydraulically actuated, providing smooth predictable braking and lower operating costs. With brakes located at each tandem wheel, the 24M offers large total brake surface area, delivering dependable stopping power and longer brake life.

Parking Brake. The spring-applied, hydraulically released multi-disc parking brake is a sealed, oil-cooled design extending component life and reducing the need for service.

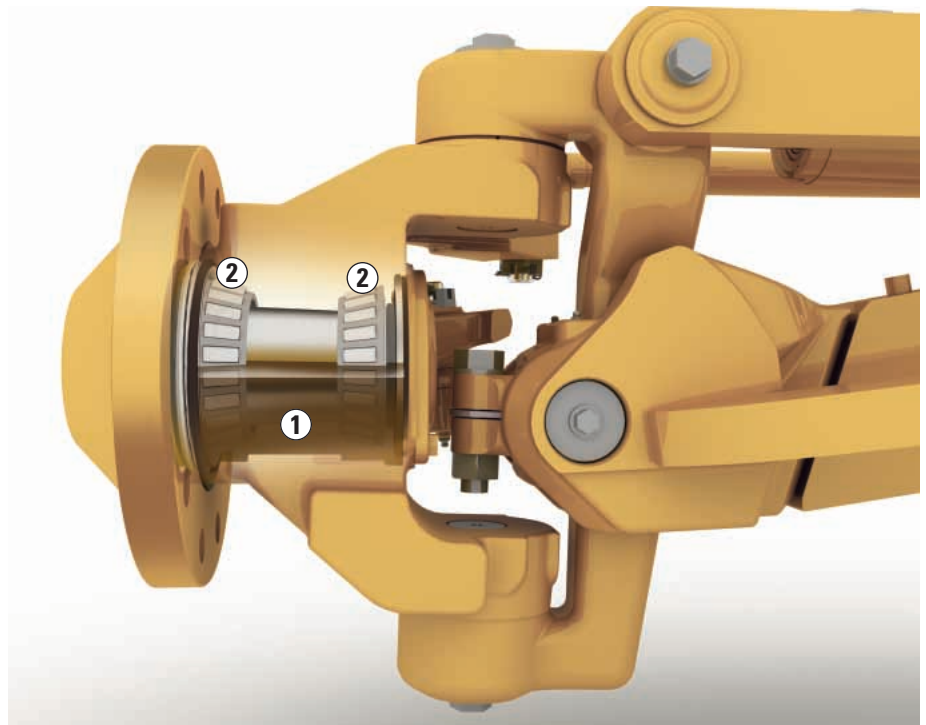

Front axle

Hydraulics

The 24M electro-hydraulics enable advanced machine controls with precise and predictable movements.



Advanced Electro-Hydraulic System.

The 24M incorporates a state-of-the-art electro-hydraulic system. This technology is the foundation for revolutionary changes of the machine and implement controls. Advanced joystick controls provide unmatched controllability with precise and predictable hydraulic movements, and the reliability you expect from Caterpillar.

Load Sensing Hydraulics (PPPC).

The time proven load-sensing system and the advanced Proportional Priority Pressure-Compensating (PPPC, or “triple-PC”) electro-hydraulic valves on the 24M are designed to provide superior implement control and enhanced machine performance in all applications. Continuous matching of hydraulic flow and pressure to power demands creates less heat and reduces power consumption.

Consistent and Predictable Movement.

PPPC valves have different flow rates for the head and rod ends of the cylinder. This ensures consistent extension and retraction speeds for each cylinder, and gives the operator a consistent and predictable response every time an implement control is moved.

Blade Float. Blade float is built into the blade lift control valves. The blade float feature allows the blade to move freely under its own weight. By floating both cylinders, the blade can follow the contours of the haul roads. Floating only one cylinder permits the toe of the blade to follow a hard surface while the operator controls the slope with the other lift cylinder.



Variable Float. The optional variable float feature lets the operator select the amount of down force the blade has when it is in float. This allows the operator to easily follow the contour of the haul road when removing only the loose material, increasing productivity and cutting edge life.

Balanced Flow. Hydraulic flow is proportioned to ensure all implements operate simultaneously with little effect on the engine or implement speeds. If demand exceeds pump capacity, all cylinder velocities are reduced by the same ratio. The result is improved productivity in all applications.

Cat® XT™ Hose. Caterpillar hose technology allows high pressures for maximum power and reduced downtime. Intelligent routing minimizes exposure to damage. Hose clips prevent hose rubbing and excessive vibration for lower owning and operating costs.

Independent Oil Supply. Large, separate hydraulic oil supply prevents cross-contamination and provides proper oil cooling, which reduces heat build-up and extends component life.

Integrated Electronic Solutions

Full systems integration optimizes machine performance and availability.

“Smart Machine”. The 24M fully integrates all core systems creating a “Smart Machine.” The Cat data link shares key data among systems, optimizing machine performance while preventing potential machine damage.



Electronic Technician (Cat ET).

Cat ET is a two-way communication tool that gives service technicians easy access to stored diagnostic data and lets them configure the machine parameters through the Cat Data Link. This integrated feature reduces machine downtime and lowers operating costs.

Diagnostics. Cat Messenger, combined with full systems integration, enhances the diagnostic capability of the 24M. Machine system errors are displayed in text as well as with fault codes, allowing service technicians and operators to quickly analyze critical data, increasing machine availability.



Machine Security System (MSS).

The optional MSS uses electronically coded keys to limit usage by specific individuals or times of the day. MSS deters theft, vandalism and unauthorized use.

Product Link. The optional Product Link system streamlines diagnostic efforts, and reduces downtime, maintenance scheduling and costs by providing a communication flow of vital machine data and location. Product Link gives automatic updates on machine parameters such as machine hours, machine condition, location, fault codes and alarms directly to your office computer.

Optional Automatic Blade Control.

The Caterpillar AccuGrade System automatically controls the blade, improving operator efficiency and productivity.

AccuGrade Attachment Ready Option.

The AccuGrade system is fully integrated into the machine design, making installation quick and easy. Integral hydraulic and electrical components are standard on the 24M (Grade Control Ready). The AccuGrade Attachment Ready Option provides additional mounting brackets, cab controls and electrical harnesses for easy installation of the Cross Slope electronics kit.



Cat Messenger.

Standard on the 24M, Cat Messenger provides real-time machine performance and diagnostic data with an easy-to-use interface. Messenger monitors all system data and alerts the operator of any faults through a digital text display that can be shown in multiple languages.

Low Battery Elevated Idle. After the 24M is at low idle for an extended period and low system voltage is detected, idle speed is raised. This ensures adequate system voltage and improves battery reliability.

Automatic Engine Deration. Protects the C18 engine by automatically lowering engine torque output and alerting the operator if critical conditions are detected.

Safety

Safety is an integral part of all machine and system designs.



Glare Reducing Paint

Operator Presence System. The Operator Presence System keeps the parking brake engaged and hydraulic implements disabled until the operator is seated and the machine is ready for safe operation.

Secondary Steering System. The standard secondary steering system automatically engages a ground driven hydraulic pump in case of a drop in steering pressure, allowing the operator to steer the machine to a stop.

Speed Sensitive Steering. The steering software automatically provides an infinitely variable ratio between the joystick and the steer tires, resulting in less sensitive steering as the ground speed increases.

Low Sound and Vibration Levels.

Isolation mounts for the cab, engine and transmission maximize operator comfort and help to minimize sound and vibration. These modifications provide a quieter and more comfortable working environment, optimizing operator focus.

Hydraulic Lockout. A simple switch located in the cab disables all implement functions while still providing machine steering control. This safety feature is especially useful while the machine is roading.

Brake Systems. Brakes are located at each tandem wheel to eliminate braking loads on the power train. In addition, the brake systems are redundant and utilize accumulators to enable stopping in case of machine failure, further increasing operational safety.

Rearview Camera. Visibility is further enhanced with an optional Work Area Vision System (WAVS) through a 178 mm (7 in) LCD color monitor in the cab. Developed specifically for rugged applications, it improves productivity and increases operator awareness of surroundings.

Blade Lift Accumulators. This standard feature uses accumulators to help absorb impact loads to the moldboard by allowing vertical blade travel. Blade lift accumulators reduce unnecessary wear and help to avoid unintended machine movement for increased operator safety.

Circle Drive Slip Clutches. Two standard circle drive slip clutches protect the drawbar, circle and moldboard from shock loads when the blade encounters an immovable object. It also reduces the possibility of abrupt directional changes in poor traction conditions, protecting the machine, operator and surroundings.

High Intensity Discharge (HID) Lighting. Optional HID lights can replace the standard halogen lamps. The powerful HID lights are four times brighter, improving night time visibility and safety.

Electrical Disconnect Switch. A battery disconnect switch provides ground-level lockout of the electrical system to prevent inadvertent starting of the machine.

Engine Shutoff Switch. An engine shutoff switch is located at ground level on the left rear of the machine, allowing anyone nearby to shut it down in case of an emergency.

Window Cleaning Platform. The optional window-cleaning platform provides an easier and safer access to all windows and improves ingress/egress to the cab with access from the rear.



Steel Tandem Walkways. Perforated raised steel walkways cover the tandems. This provides a sturdy platform for standing and walking, and additional protection for the brake lines. A stairway lamp illuminates the walkway and can be activated at ground level during entry and shut off with a switch in the cab.

Dual Exits. The operator has dual exits from the machine allowing for emergency egress should one side become obstructed.

Fire Suppression Mounting Plate. The standard fire suppression mounting plate places the tanks in the optimum position for improved visibility, ingress/egress and durability.

Rear Fenders. To help reduce objects flying from the tires, as well as a build-up of mud, snow or debris, optional rear fenders can be added.

Additional Safety Features. The 24M has many additional standard safety features, including laminated glass on the front window, back-up lights, sounding alarm, lockable doors, black glare-reducing paint on the front frame, engine enclosure and lift arms and conveniently located grab rails for added safety.

Serviceability and Customer Support

Simplified service, world-class product support and Cat dealer-trained experts keep your fleet up and running, maximizing your equipment investment.



Grouped Service Points. The 24M groups daily service points in the left side service center to help ensure proper maintenance and inspection routines.

Extended Service Intervals. The 24M extended service intervals, such as 500-hour engine oil changes and 4000-hour hydraulic oil changes, reduce machine service time and increase availability.

Fast-Fill Fuel. The 24M offers a standard Fast-Fill that allows customers to refuel in less than four minutes for fast, accurate filling and reduced downtime.

Ecology Drains. Conveniently located ecology drains shorten service times and help keep the environment safe by preventing spills.

Automatic Lubrication System. The standard Lincoln Centro-Matic AutoLube System maintains the proper grease lubrication on working surfaces, significantly extending component life. Contaminants are purged from open pins and bushings to help prevent dirt from damaging critical components.

Grouped Components Rebuilds.

Rebuilds take your machine out of service. Caterpillar designs components to be rebuilt in groups, maximizing uptime.

Diagnostics and Monitoring. The 24M integrates Cat Messenger, Cat Electronic Technician and S•O•SSM Sampling ports for easy monitoring and fast troubleshooting, keeping your machine up and running.

Machine Selection. Make detailed comparisons of the machines under consideration before purchase. Cat dealers help you size the right machine for your operations and can estimate component life, preventative maintenance cost, and the true cost of production.

Purchase. Consider the financing options available, as well as day-to-day operating costs. Look at dealer services that can be included in the cost of the machine to yield lower equipment owning and operating costs over the long run.

Maintenance Services. Repair option programs guarantee the cost of repairs up front. Diagnostics programs such as Scheduled Oil Sampling, S•O•SSM analysis, Coolant Sampling and Technical Analysis help avoid unscheduled repairs.

Product Support. You will find nearly all parts at our dealer parts counter. Cat dealers use a world-wide computer network to track in-stock parts to minimize machine down time. Save money with genuine Cat Reman parts. You receive the same warranty and reliability as new products at substantial cost savings.

Engine

Base Power (all gears) – Net	397 kW	533 hp
Engine Model	Cat® C18 ACERT™	
Displacement	18.1 L	1,104.5 in ³
Bore	145 mm	5.7 in
Stroke	183 mm	7.2 in
Max torque	2389 N·m	1,762 ft·lb
Speed @ rated power	1,800 rpm	
Number of cylinders	6	
Derating altitude	3352 m	11,000 ft
Std – Fan speed – max	1,300 rpm	
– min	60 rpm	
Std – Ambient Capability	50° C	122° F

- Net power is tested per ISO 9249, SAE J1349, and EEC 80/1269 standards in effect at the time of manufacture
- Net power advertised is the power available at a rated speed of 1,800 rpm, measured at the flywheel when engine is equipped with fan running at minimum speed, air cleaner, muffler and alternator
- No engine derating required up to 3352 m (11,000 ft)

Power Train

Forward/Reverse Gears	6 Fwd/3 Rev	
Transmission	Automatic, electronic power shift	
Brakes – service	Oil-actuated, oil-disc	
– service, surface area	101 508 cm ²	15,733 in ²
– parking	Spring applied, hydraulically released	
– secondary	Oil-actuated, oil-disc	

Hydraulic System

Circuit type	Electro-hydraulic load sensing, closed center	
Pump type	Variable piston	
Pump output	550 L/min	145 gal/min
Maximum system pressure	24 150 kPa	3,500 psi
Standby Pressure	3100 kPa	450 psi

- Pump output measured at 2,150 rpm

Operating Specifications

Top Speed – Fwd	43 km/h	26.7 mph
– Rev	41.2 km/h	25.6 mph
Turning Radius (outside front tires)	12.4 m	40 ft 9 in
Steering range – left/right	47.5°	
Articulation Angle – left/right	25°	
Fwd. 1st	3.6 km/h	2.3 mph
2nd	5.7 km/h	3.5 mph
3rd	9.6 km/h	6 mph
4th	15 km/h	9.3 mph
5th	27.7 km/h	17.2 mph
6th	43 km/h	26.7 mph
Rev. 1st	5.4 km/h	3.4 mph
2nd	14.3 km/h	8.9 mph
3rd	41.2 km/h	25.6 mph

Service Refill

Fuel Capacity	1326 L	350 gal
Cooling System	90 L	24 gal
Hydraulic system – total	264 L	70 gal
– tank	135 L	36 gal
Engine Oil	60 L	16 gal
Transmission Oil	87.1 L	23 gal
Differential/Final Drives	184 L	49 gal
Tandem housing (each)	322 L	85 gal
Front wheel spindle bearing housing	4 L	1 gal
Circle drive housing (each)	7.5 L	2 gal

Frame

Circle – diameter	2631 mm	103.6 in
– blade beam thickness	160 mm	6.3 in
Drawbar – height	215 mm	8.5 in
– thickness	16 mm	0.6 in
– width	225 mm	8.9 in
Front-top/bottom plate – width	514 mm	20.2 in
– thickness	50 mm	2 in
Front-side plates – width	415 mm	16.3 in
– thickness	25 mm	1 in
Front axle – height to center	817 mm	32.2 in
– wheel lean, left/right	18°	
– total oscillation per side	32°	
Height – front axle center	858 mm	33.8 in

Tandems

Height	1040 mm	41 in	
Width	353 mm	13.9 in	
Sidewall thickness	– inner	25 mm	1 in
	– outer	30 mm	1.2 in
Drive chain pitch	76 mm	3 in	
Wheel axle spacing	2285 mm	90 in	
Tandem oscillation	– front up	20°	
	– front down	20°	

Moldboard

Width	7.3 m	24 ft	
Height	1067 mm	42 in	
Thickness	50 mm	2 in	
Arc radius	550 mm	21.7 in	
Throat clearance	162 mm	6.4 in	
Cutting edge	– width	330 mm	13 in
	– thickness	29 mm	1.1 in
End Bit	– width	203 mm	8 in
	– thickness	25 mm	1 in

Blade Range

Circle centershift	– right	5338 mm	210.2 in
	– left	5332 mm	209.9 in
Moldboard sideshift	– right	4902 mm	193 in
	– left	4528 mm	178.3 in
Maximum blade position angle	35°		
Blade tip range	– forward	40°	
	– backward	0°	
Maximum shoulder reach outside of tires	– right	3228 mm	127.1 in
	– left	3222 mm	126.9 in
Maximum lift above ground	634 mm	25 in	
Maximum depth of cut	657 mm	25.9 in	

Ripper

Ripping depth, maximum	454 mm	17.9 in	
Ripper shank holders	7		
Shank holder spacing	– min	593 mm	23.4 in
	– max	604 mm	23.8 in
Penetration force	11 851 kg	26,138 lb	
Pryout force	17 386 kg	38,330 lb	

Weights

Gross Vehicle Weight – base		
– total	62 457 kg	137,694 lb
– front axle	18 862 kg	41,584 lb
– rear axle	43 595 kg	96,110 lb
Gross Vehicle Weight – max		
– total	66 138 kg	145,808 lb
– front axle	19 907 kg	43,887 lb
– rear axle	46 231 kg	101,921 lb

- Base operating weight calculated on standard machine configuration with 29.5-29 28PR tires, full fuel tank, coolant, lubricants and operator.

Standards

ROPS/FOPS	ISO 3471/ISO 3499
Steering	ISO 5010:1992
Brakes	ISO 3450
Sound	ISO 6394/ISO 6395

- The static operator sound pressure level measured according to ISO 6394:1998 for a cab offered by Caterpillar, when properly installed, maintained and tested with doors and windows closed and hydraulic fan at maximum speed, is less than 73 dB(A).
- The dynamic spectator sound power level for the standard machine measured according to ISO 6395:1988 with no sound suppression package and hydraulic fan running at maximum speed is 115 dB(A). When machine is equipped with sound suppression package and hydraulic fan running at 70% of maximum speed, machine sound measured is less than 111 dB(A), complying with EU 2000/14/EC requirement.

Dimensions

All dimensions are approximate, based on standard machine configuration with 29.5-29 28PR tires.

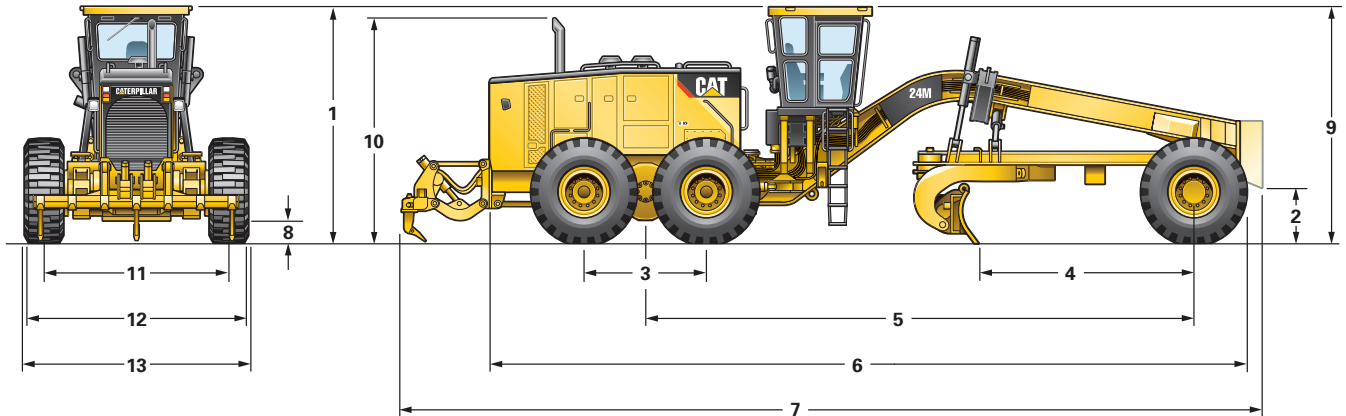

1	Height – top of cab	4452 mm	175.3 in
2	Height – front axle center	858 mm	33.8 in
3	Length – between tandem axles	2285 mm	90 in
4	Length – front axle to moldboard	4048 mm	159.4 in
5	Length – front axle to mid tandem	10 278 mm	404.6 in
6	Length – front tire to end of rear frame	14 194 mm	558.8 in
7	Length – counterweight to ripper	16 102 mm	633.9 in

8	Ground clearance at rear axle	607 mm	23.9 in
9	Height to top of cylinders	3846 mm	151.4 in
10	Height to exhaust stack	4322 mm	170.2 in
11	Width – tire center lines	3450 mm	135.8 in
12	Width – outside rear tires	4225 mm	166.3 in
13	Width – outside front tires	4280 mm	168.5 in

Standard Equipment

Standard equipment may vary. Consult your Caterpillar® dealer for details.

OPERATOR ENVIRONMENT

- Air conditioner/heater, modular
- Armrest, adjustable
- Articulation, automatic Return-to-Center
- Ashtray and lighter
- Cat Messenger, operator information system
- Coat hook
- Cup holder
- Display, digital speed and gear
- Door, driver access (left and right sides)
- Fan, defroster, rear window
- Gauges – articulation, engine coolant temp, engine RPM, fuel, system voltage
- Hour meter, digital
- Joystick hydraulic controls
 - implements, steering, transmission
- Lights, night time cab
- Mirror, inside rearview, wide angle
- Power port, 12V
- Precleaner, Cab HVAC
- ROPS cab, sound suppressed
- Seat, air suspension, cloth
- Seat belt, retractable 76 mm (3 in)
- Storage area for cooler/lunchbox
- Sun shade
- Throttle control, electronic
- Windows, laminated glass:
 - front with intermittent wiper/washer
- Windows, side and rear (3)
- Wiper/washer, rear
- Wrist rests, adjustable

POWER TRAIN

- Air cleaner, dual stage, dry type, automatic dust ejector,
 - service indicator through Cat Messenger
- Air-to-air after cooler (ATAAC)
- Belt, serpentine, automatic tensioner
- Brakes, four-wheel hydraulic
- Differential, lock/unlock
- Electronic over speed protection
- Engine, Cat® C18 with ACERT™ Technology
- Ether starting aid
- Fuel tank, fast fill, ground level
- Fuel-water separator
- Hydraulic demand fan
- Muffler, under hood
- Parking brake – multi-disc, sealed, oil-cooled
- Priming pump, fuel
- Rear axle, modular
- Sediment drain, fuel tank
- Transmission, 6F/3R, power shift
- Transmission, autoshift

ELECTRICAL

- Alarm, back up
- Alternator, 150 ampere, sealed, filtered air intake
- Batteries, maintenance free, 1,500 CCA
- Breaker panel
- Electrical system, 24V
- Grade Control Ready – Cab harness, software,
 - electrical hydraulic valves, bosses and brackets
- Lights, reversing
- Lights, stop and tail, LED
- Product Link Ready
- Starter, electric, heavy-duty
- Starting receptacle, plug-in
- Wiring for communications radio
- Wiring for roof mounted beacon

OTHER STANDARD EQUIPMENT

- Accumulators, blade lift
- Auto-lube, Lincoln, Centro-Matic
- Brake accumulators, dual certified
- Bumper, rear, integrated with hitch
- Clutch, circle drive slip (2)
- Cutting edges
 - curved DH-2 steel
 - 330 mm × 28 mm (13 in × 1.1 in)
- Doors (8), engine compartment, locking
- Drain, ecology, engine oil, high-speed (Wiggins)
- Drawbar – 8 shoe with replaceable wear strips
- Endbits, 25 mm (1 in) DH-2 steel
- Extended Life Coolant to –50° C (–58° F)
- Frame, articulated, with safety lock
- Ground level engine shutdown
- Ground level fueling
- Guards, valve
- Horn, electric (2)
- Hydraulics, base 8 implement controls
- Hydraulics, load-sensing
- Lockout, hydraulic implement for roading
- Moldboard
 - 7315 mm × 1076 mm × 50 mm (24 ft × 42 in × 2 in)
 - hydraulic sideshift and tip
- Paint, glare reducing – top of front frame, rear enclosure and lift arms
- Radiator cleanout access
- Ripper, rear
- Secondary steering
- Serviceability, LH side
- S•O•SSM ports: engine, hydraulic, transmission, coolant, fuel
- Tandem walkway/guards

TIRES, RIMS, & WHEELS

- Partial allowance for tires and multi-piece rims

Optional Equipment

Optional equipment may vary. Consult your Caterpillar® dealer for details.

	kg	lb
ELECTRICAL		
Converter, communications	2	5
Lights: Lighting arrangements, plus HID options		
Warning: Beacon		
GUARDS		
Guard, transmission	227	500
Guards, mud	23	50
OPERATOR ENVIRONMENT		
Access, dual platform	635	1,400
Access, left hand platform	374	825
Mirrors, outside:		
Heated 24V	14	30
Mounted	13	28
Radio ready, AM/FM or Satellite	2	5

	kg	lb
POWER TRAIN		
Engine, compression brake		
OTHER ATTACHMENTS		
AccuGrade ARO	18	40
Camera, rearview	9	20
Caterpillar Product Link 321SR	5	10
Fenders, rear	574	1,265
Float, variable	91	200
Horn, air	7	15
Security system	2	5
Sound suppression	28	62
Starting, cold weather	77	169
240 V heaters for hydraulic oil and jacket water		
WORK TOOLS/G.E.T.		
Cutting Edges		
Push plate, counterweight	269	592
Ripper tooth	72	158

Notes

24M Motor Grader

For more complete information on Cat products, dealer services,
and industry solutions, visit us on the web at www.cat.com

© 2007 Caterpillar
All Rights Reserved
Printed in U.S.A.

Materials and specifications are subject to change without notice.
Featured machines in photos may include additional equipment.
See your Caterpillar dealer for available options.

CAT, CATERPILLAR, ACERT, AccuGrade, XT, their respective logos, "Caterpillar Yellow"
and the POWER EDGE trade dress, as well as corporate and product identity used herein,
are trademarks of Caterpillar and may not be used without permission.

AEHQ5735-01 (8-07)

Replaces AEHQ5735

CATERPILLAR[®]